

Instructions







Model Select Table

| Model # | Description | Unit |
|---------|--|------|
| 4123 | 4" (100mm) base with three different size shields | Set |
| 401 | 4-1/4" x 8" (110mm x 200mm) Flat shield | Pkg |
| 402 | 9" x 8" (180mm x 200mm) One angle shield | Pkg |
| 403 | 4-1/4" x 11-1/2" (110mm x 290mm) Two angle shield | Pkg |
| 6123 | 6" (150mm) base with three different size shields | Set |
| 601 | 5-1/2" x 8" (140mm x 200mm) Flat shield | Pkg |
| 602 | 8" x 9-1/2" (200mm x 240mm) One angle shield | Pkg |
| 603 | 5-1/2" x 15" (140mm x 380mm) Two angle shield | Pkg |
| Notes | 4123/6123 sets include: one base, one chip brush and 3 different shape/angle shields. 401/402/403/601/602/603 packages include: 3pcs of the same type of shield. | |

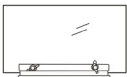
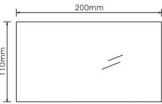
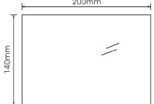
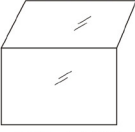
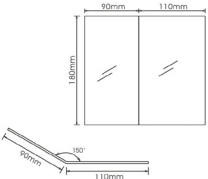
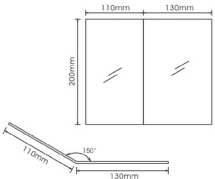
This chip protection unit is designed to protect your milling, drilling and other machining operations at a very low cost. Its flexibility allows you to put it on machine tables and vises at any angle and position to protect the operators. Even though it uses magnetic power to position itself, it is very easy to store with the magnetic cover. The brush can be used to clean any chips sticking to the bottom of the base.

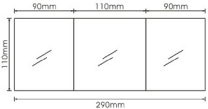
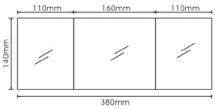
There are 4" and 6" long base sets. You can select from the table to the left for your applications. Each individual set includes: one chip protect base, three chip protect shields, one magnetic cover and one chip brush. All the parts can be replaced and are interchangeable.

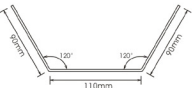
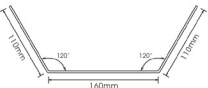
Patent pending.....

| Sets Include | Replaceable Shields | |
|---|---|---|
|  <p>Base & Flat Shield</p> |  <p>Model #401</p> |  <p>Model #601</p> |
|  <p>150° One Angle Shield</p> |  <p>Model #402</p> |  <p>Model #602</p> |
|  <p>120° Two Angle Shield</p> |  <p>Model #403</p> |  <p>Model #603</p> |
|  <p>Magnetic Cover</p> |  <p>Model #403</p> |  <p>Model #603</p> |
|  <p>Brush</p> | | |