

IMPORTANT! Read carefully before operating this tool.

Failure to operate any power tool properly can result in personal injury and/or property damage!



7.2.2.3 GENERAL SAFETY RULES

- Multiple hazards. Read and understand the safety instructions before installing, operating, repairing, maintaining, changing accessories on, or working near the power tool. Failure to do so can result in serious bodily injury.
- Only qualified and trained operators should install, adjust or use the power tool.
- Do not modify this power tool. Modifications may reduce the effectiveness of safety measures and increase the risks to the operator.
- Do not discard the safety instructions – give them to the operator.
- Do not use a tool if the tool has been damaged.
- Warnings shall be given against the risk of explosion or fire due to the material being processed.
- Warnings shall be given against the risk of cutting.



7.2.2.4 PROJECTILE HAZARDS

- Failure of the work piece, of accessories, or even of the tool itself may generate high velocity projectiles.
- Always wear impact-resistant eye protection during operation of the tool. The grade of protection required should be assessed for each use.



7.2.2.5 ENTANGLEMENT HAZARDS

- Entanglement hazard - choking, scalping and/or lacerations can occur if neck ware, hair or gloves are not kept away from tool and accessories.

7.2.2.6 OPERATING HAZARDS

- Use of the tool may expose the operator's hands to hazards including crushing, impacts, cuts and abrasions and heat. Wear suitable gloves to protect hands.
- Operators and maintenance personnel must be physically able to handle the bulk, weight and power of the tool.
- Hold the tool correctly: be ready to counteract normal or sudden movements – have both hands available.
- Maintain a balanced body position and secure footing.
- Keep hands away from rotating or reciprocation accessories, spindles or other moving parts.
- Release the start and stop device in the case of an interruption of the energy supply
- Use only lubricants recommended by the manufacturer.



7.2.2.7 REPETITIVE MOTIONS HAZARDS

- When using a power tool, you may experience discomfort in your hands, arms, shoulders, neck, or other parts of your body.
- While using a power tool, position your body in a comfortable posture. Maintain secure footing and avoid awkward or off-balanced postures. Changing your posture during extended tasks may help avoid discomfort and fatigue.
- If you experience symptoms such as persistent or recurring discomfort, pain, throbbing, aching, tingling, numbness, burning sensation, or stiffness, do not ignore these warning signs. Promptly tell your employer and consult a qualified health professional.

7.2.2.8 ACCESSORY HAZARDS

- Only use sizes and types of accessories and consumables that are recommended by the power tool manufacturer.



7.2.2.9 WORKPLACE HAZARDS

- Slips, trips and falls are major causes of workplace injury. Be aware of slippery surfaces caused by use of the tool and also of trip hazards caused by the air line or hydraulic hose.
- Proceed with care in unfamiliar surroundings. Hidden hazards may exist, such as electricity or other utility lines.
- This power tool is not intended for use in potentially explosive atmospheres and is not insulated from coming into contact with electric power.
- Make sure there are no electrical cables, gas pipes etc. that could cause a hazard if damaged by use of the tool.



7.2.2.10 DUST AND FUME HAZARDS

- Dust from some work processes can cause cancer, birth defects or other respiratory diseases. Risk assessment of these hazards and implementation of appropriate controls is essential.

- If the pneumatic tool is used in a dust filled environment exhaust air can cause a dust hazard.
- Dusts and fumes generated when using power tools can cause ill health (for example: cancer, birth defects, asthma and/or dermatitis); risk assessment of these hazards and implementation of appropriate controls of is essential.
- Risk assessment should include dust created by the use of the tool and the potential for disturbing existing dust.
- Operate and maintain the power tool as recommended in these instructions, to minimize dust or fume emissions
- Direct the exhaust so as to minimized disturbance of dust in a dust filled environment
- Where dusts or fumes are created, the priority shall be to control them at the point of emission.
- All integral features or accessories for the collection, extraction or suppression of airborne dust or fumes should be correctly used and maintained in accordance with the manufacturer's instructions.
- Select, maintain and replace the consumable/inserted tool as recommended in these instructions, to prevent an unnecessary increase in dust or fumes.
- Use respiratory protection as instructed by your employer or as required by occupational health and safety regulations;



7.2.2.11 NOISE HAZARDS

- Unprotected exposure to high noise levels can cause permanent, disabling, hearing loss and other problems such as tinnitus (ringing, buzzing, whistling or humming in the ears).
- Risk assessment of these hazards and implementation of appropriate controls of is essential.
- Appropriate controls to reduce the risk may include actions such as damping materials to prevent work pieces from 'ringing'
- Use hearing protection as instructed by your employer or as required by occupational health and safety regulations;
- Operate and maintain the power tool as recommended in these instructions, to prevent an unnecessary increase in noise levels;
- Select, maintain and replace the consumable/inserted tool as recommended in these instructions, to prevent an unnecessary increase in noise.



7.2.2.12 VIBRATION HAZARDS

- Exposure to vibration can cause disabling damage to the nerves and blood supply of the hands and arms;
- Wear warm clothing when working in cold conditions and keep your hands warm and dry.
- If you experience numbness, tingling, pain or whitening of the skin in your fingers or hands, stop using the power tool, and tell your employer. You should also seek medical advice from a qualified occupational health professional.
- Operate and maintain the power tool as recommended in these instructions, to prevent an unnecessary increase in vibration;
- Select, maintain and replace the consumable/inserted tool as recommended in these instructions, to prevent an unnecessary increase in vibration levels;
- Support the weight of the tool in a stand, tensioner or balancer, because the operator can then use a lighter grip to support the tool.
- Hold the tool with a light but safe grip taking account of the required hand reaction forces, because the risk from vibration is generally greater when the grip force is higher.

7.2.3 ADDITIONAL SAFETY INSTRUCTIONS FOR PNEUMATIC POWER TOOLS - AIR SUPPLY & CONNECTION HAZARDS

- Air under pressure can cause severe injury.
- Never direct air at yourself or anyone else.
- Whipping hoses can cause severe injury. Always check for damaged or loose hoses and fittings.
- Whenever universal twist couplings (claw couplings) are used, lock pins must be installed.
- Do not exceed the maximum air pressure stated on the tool.
- Use whip check safety cables to safeguard against possible hose to tool and hose to hose connection failure.
- Never carry an air tool by the hose.

Read Operating Instructions

Always become familiar with all the instructions and warnings before operating any power tool.



Always Wear Approved Eye Protection

Impact resistant eye protection should meet or exceed the standards as set forth in the United States ANSI Z87.1, Occupational and Educational Eye and Face Protection. Look for the marking Z87.1 on your eye protection to insure that it is an approved style. For further information, ANSI Z87.1, Occupational and Educational Eye and Face Protection, is available from the American National Standards Institute, Inc., 11 West 42nd Street, New York, NY 10036.



Hearing Protection is Recommended

Hearing protection should be used when the noise level exposure equals or exceeds an 8 hour time-weighted average sound level of 85 dBA. Process noise, reflective surfaces, other tools being operated nearby, all add to the noise level present in your work area. If you are unable to determine your noise level exposure, we recommend the use of hearing protection.



Avoid Prolonged Exposure to Vibration

Tools can vibrate during use. Prolonged exposure to vibration or very repetitive hand and arm movements, can cause injury. Stop

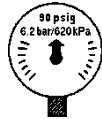

90 PSIG Maximum

This tool is designed to operate at an air pressure of 90 pounds per square inch gauge pressure (90 PSIG) maximum, at the tool. Use of higher air pressure can, and may cause injury. Also, the use of higher air pressure places the internal components under loads and stresses they were not designed for, causing premature failure. The air supply should be clean and dry, preferably lubricated. For best results, drain the moisture from your compressor daily.

WARNING:

Some dust created by power sanding, sawing, grinding, drilling, and other construction activities contains chemicals known to cause cancer, birth defects or reproductive harm. Some examples of these chemicals are:

- Lead from lead-based paints
- Crystalline silica from bricks, cement and other masonry products
- Arsenic and chromium from chemically treated lumber

Your risk from these exposures varies, depending on how often you do this type of work. To reduce your exposure to these chemicals, work in a well-ventilated area and work with approved safety equipment such as those dust masks that are specially designed to filter out microscopic particles.

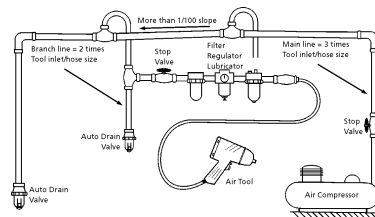

using any tool if discomfort, tingling feeling or pain occurs. You should consult your physician before resuming use of the tool.

Description

The Universal Tool Superhand Air File is designed to file small areas with restricted access with ease. This reciprocating air file weighs just over two pounds for easy one-handed operation. Features include a hanging bail for easier handling, a thumb switch throttle for easy start-up, and a durable steel housing. Able to file steel, plastic, wood and aluminum. It's 1/4" stroke length makes quick work of most jobs. Includes 4 assorted files: flat, round, triangular and bastard cut.



devices as furnished by the manufacturer. Where an air tool is modified or altered, the modifier shall provide the safeguards to enable it to be safely used in the operations intended and to comply with any applicable provisions as contained in ANSI B186.1.

Safety Instructions

The following instructions are furnished as general guidelines for use of your pneumatic tool. They cannot comprehensively cover all possible or conceivable uses of the subject tool. For additional information on the safe use of air tools, we advise you to obtain a copy of ANSI B186.1 Safety Code for Portable Air Tools, available from the following source:

American National Standards Institute, Inc.
11 West 42nd Street
New York, NY 10036.

The use of the word "shall" in the following instructions, indicates that adherence to the particular requirement is necessary to conform to ANSI B186.1.

Tool Application and Usage

Portable tools shall be used only for the purposes intended in their design and within the capacity for which they were intended and rated. It shall be the tool owner's and/or employer's responsibility to instruct each operator in the safe use of the tool. Tools shall not be used without guards and safety

Tool Installation

Pressure regulators shall be used to limit air pressure to the rated pressure where the supply pressure exceeds the tool's rated pressure. Air hoses and lines shall be relieved of compressed air before being disconnected or disjoined, unless there is automatic valve closing protection at the joint being separated. Synthetic lubricants which can cause deterioration of elastomer seals shall not be used in air systems of air tools.

Tool Maintenance

It shall be the tool owner's and/or employer's responsibility to assure that tools are maintained in a safe operating condition. Tool maintenance and repair shall be performed by authorized, trained, competent personnel. Tools shall be disconnected from their compressed air supply before repairs are attempted. Repairs shall be consistent with the manufacturer's recommended procedures. Tool, hoses and fittings shall be replaced if unsuitable for safe operation. It shall be the tool owner's and/or employer's responsibility to keep required rating markings and warnings on the tool in legible condition.

Specifications

File Size	4" x 1/4" Round Shaft
Free Speed	9,000 SPM
Stroke length	1/4"
Weight	2-1/4 lbs.
Length	7"
Average air consumption	4 CFM
Recommended hose size	3/8" ID
Air inlet	1/4" NPT
Maximum operating pressure	90 PSIG

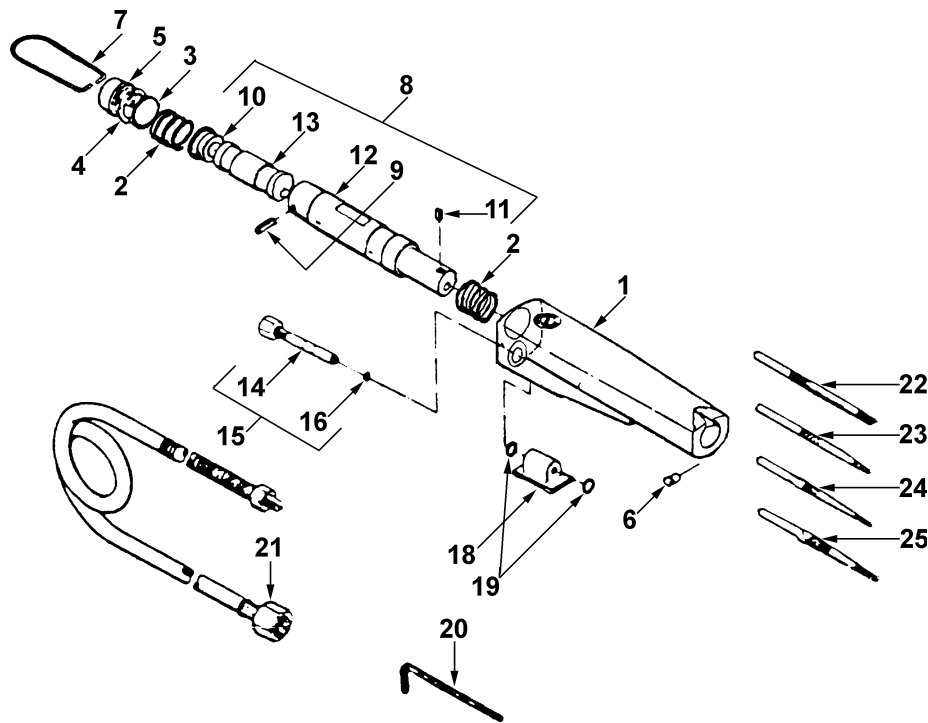
Parts Breakdown for UT8862

Replacement Parts for UT8862

Ref.	Description	Part #	Ref.	Description	Part #
1	Housing	9705001	14	Valve nipple	9705014
2	Spring (2)	9705002	15	Valve nipple ass'y (14,16)	9705015
3	Filter	9705003	16	O-Ring	9705016
4	Retaining ring	9705004	17	Valve assembly	9705018
5	Cap	9705005	18	Valve body	9705019
6	Guide key	9705006	19	O-Ring (2)	9705020
7	Hangar	9705007	20	3mm Hex wrench	9705021
8	Cylinder assembly (9-13)	9705008	21	Hose assembly	9705022
9	Spring pin	9705009	22	3 Pk of Flat Mill Cut Files	5679
10	Plug	9705010	23	3 Pk of Round Single Cut	5680
11	Headless set screw	9705011	24	3 Pk of Triangle Single Cut	5681
12	Cylinder	9705012	25	3 Pk of Flat Bastard Cut	5682
13	Piston	9705013	*	4 Pk Asstd. (1 ea. above*)	5683

Universal Tool's Limited Warranty

Universal Tool warrants their tools to be free from defects in material and workmanship for one year from the date of purchase. This warranty does not apply to tools which have been abused, misused, modified or repaired by someone other than Universal Tool or their authorized service centers. If a Universal Tool tool proves defective in material or workmanship within one year after purchase, return it to any authorized service center or Universal Tool freight prepaid. Please enclose your name, address and adequate proof of purchase and a short description of the defect. Universal Tool will, at their option, repair or replace defective tools, free of charge. Repairs or replacements are warranted as described above for the remainder of the original warranty period. Universal Tool's sole liability and your exclusive remedy under this warranty is limited to repair or replacement of the defective tool. There are no other warranties expressed or implied and Universal Tool shall not be liable for incidental, consequential or special damages, or any other damages, costs or expense of repair or replacement as described above.

⚠ WARNING - Do not use excessive force while filing.

⚠ CAUTION - Always wear eye protection during use.