

OTMT

GEAR DRIVE MILL/DRILL MACHINE



ITEM NO.87-115-145
MODEL NO.OT7045FG

Version date: 11/07/2014

Please Read These Instructions Before Operating Your Machine
Contents Subject To Change Without Notice

CONTENTS

Safety Warning	1
Specification	1
Features	2
Installation	3
Operation	3
Electrical System	5
Trouble Shooting	6
Maintenance	7
Table Assembly	8
Table Assembly Part List	8
Headstock Assembly	10
Headstock Assembly Part List	11
Spindle Assembly	14
Spindle Assembly Part List	15



SAFETY WARNING

1. Read all instructions before using this machine.
2. Keep guards in place and in working order.
3. Keep work area clean, cluttered area invite injuries.
4. Keep children and visitors away from work area.
5. Dress properly, no loose clothing, gloves, neckties, or other jewelry to get caught in moving parts, wear protective hair covering to contain long hair.
6. Always wear eye protection, also use face or dust mask if operation is dusty.
7. Remove adjusting keys and wrenches from tool before starting.
8. Be sure drill bit or cutting tool is securely locked in the chuck.
9. Avoid unintentional starting.
10. Keep proper footing and balance at all times, do not reach over or across running machines.
11. Maintain tools with care, keep tools sharp and clean for better and safer performance.
12. Do not operate this machine while the influence of drug, alcohol or any medication.
13. Use the right tool for the job. Do not attempt to force a small tool or attachment to do the work of a larger industrial tool.
14. Ensure this machine is properly grounded.
15. Secure workpiece to keep workpiece from rotating With the drill bit or cutting tool.

SPECIFICATIONS

Model	OT7045FG
Max. drilling capacity	1.77"(45mm)
Max. face mill capacity	3.15"(80mm)
Max. end mill capacity	1.10"(28mm)
Max. tapping capacity	M12
Max. spindle stroke	5.12"(130mm)
Max. distance from spindle axis to column	10.24"(260mm)
Swivel angle of headstock at perpendicular direction	± 90°
Max. distance between spindle nose to table	26.77"(680mm)
Spindle taper	R8
Working area of table	31.50" × 9.45"(800mm × 240mm)
Forward and backward travel of table	6.89"(175mm)
Left and right travel of table	20"(500mm)
Spindle speeds (4P)	50HZ: 80,145,260,375,710,1250 RPM
	60HZ: 95,175,310,450,850,1500 RPM
Motor	1HP
Overall size:(without stand)	33"X42"X40"(820mmX1060mmX1020mm)
Packing size:(without stand)	31"X35"X46"(770mmX880mmX1160mm)
Weight	805LBS

Standard accessories	Double end Wrench
	Allen wrench 0.12"(3mm),0.16"(4mm), 0.2"(5mm),0.24"(6mm)
	Screwdriver(-)6"
	Drill stock
	Wedge
	Drawbar
	Drawbar washer

FEATURES

1. This machine may be used for surface cutting, drilling, milling, and tapping.
2. This machine is of fine quality, can be operated easily, it is not limited to skilled operator.
3. The drilling and milling operation can be performed by two methods:
 - Hand operation, which makes quick feedin drilling.
 - Worm gear feed operation, which makes slow feeding milling.
4. Many of the adjustable nuts are bronze, for adjusting thread clearance and reducing wear. These bronze parts also allow screws to rotate smoothly and improve accuracy.
5. The vertical column is very strong and stiff, which makes the machine very stable and improves accuracy of manufactured parts.
6. The machine headstock is cast iron, it has been heat-treated, stress-relieved, and precision machined.
7. Machine gears are precision ground for smooth operation.
8. Speeds can be easily changed.
9. Tapping can be done in either rotation, working depth can be controlled by using a positive stop gauge.
10. The head can be turned in two rotation for a satisfying desired angle.

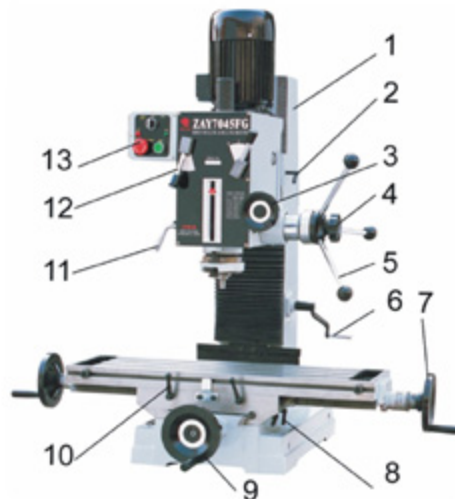

1	square column	8	cross lock screw
2	lock screw	9	longitudinal lock screw
3	micro feed handwheel	10	lock handle
4	lock handle	11	shift handle
5	feed handle	12	change speed handle
6	crank	13	switch
7	handwheel		

INSTALLATION

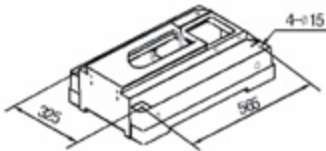

- 1.Ensure the headstock is as lower as possible, and be fixed on the column tightly before moving machine. While moving machine, keep its balance and safety.
- 2.Don't mount the machine at the sunshine place to avoid the deformity of machine and the loss of accuracy.

- 3.Mount machine to a sturdy table or a solid concrete foundation, it's advisable that the base you choose be well constructed to avoid any vibration during operation.
- 4.Thoroughly clean the machine with a commercial degreaser, and then coat all bright metal with a light lubricant to prevent corrosion.
- 5.Level the surface of the worktable on both lengthwise and crosswise by using a precision level.
- 6.Remove the oil filler plug and fill the oil to the gear box until the oil level reaches the middle of the oil fluid level indicator. Lubricate all points.

OPERATION

Notice: Check all parts and safety precautions for proper condition before operation

USE OF MAIN MACHINE PARTS

1. Raise and lower the headstock on its rack and pinion mechanism by using the head crank. When the desired height is reached, tighten the bolts to avoid vibration.
2. Head may be rotated 360° by loosening the same bolts mentioned above. Adjust the head to the desired angle, then tighten the heavy duty head lock nuts.
3. For auto-tapping electrical system, The knob is setted for MILLING & DRILLING, TAPPING AND STOP. The mushroom head red push button for emergency stop while milling and drilling, or reverse while tapping, The green push button for starting.
4. Feed the spindle using spindle feeding handle, Micro feed the spindle using the spindle micro feeding handle
5. Move the table from side to side by using the lengthwise table feed wheel, and from front to back by using the cross table feed wheel.
6. Adjust the positive depth stop gauge according to working depth.
7. Adjust the scale size according to working need.

DRILLING OPERATION

1. For drilling blind hole (which do not pass through the workpiece),turn off the knob make loose the taper body of worm gear and spring base, then adjust the positive depth stop gauge so that the distance from the tip of the drilling bit to the end of the blind hole is equal to the desired depth.
2. For drilling pass hole (which pass through the workpiece),set the positive depth stop gauge in its uppermost position.

MILLING OPERATION

1. Adjust the positive stop depth gauge to its uppermost position.
2. Using the spindle feed handle, adjust the cutter to approximately the correct height, turn off the knob, tighten the taper body of worm gear and spring base.
3. Set the working depth by using the micro feed handle.
4. Lock the rack sleeve at the height with the fixed bolt.

- When milling in the table longitudinal, it is a good idea to lock the across feeding table to ensure the accuracy of your work. To do this, tighten the two screws located on the right side of the table base.
- When cross feeding milling, lock the longitudinal feeding travel, do this by tightening the two screws on the front of the table base.

TAPPING OPERATION

- Loosen the knob in the center of the spindle feed handle.
- Adjust the positive depth gauge to the required position.
- Then switch point to tapping When tapping is overload, press down the red emergency switch, and the spindle reverse, the taper turn out.

ADJUSTMENT

- Adjustable moveable fixed rings are mounted on the front of the table to limit cross travel.
- Your machine is equipped with gib strip adjustment to compensate for wear and excess slack on cross and longitudinal travel.
- Rotate the gib strip bolt slightly clockwise to tighten the gib trip. Rotate it slightly counter-clockwise to loosen the gib trip.
- Adjust the gib trip bolt until very slight drag is felt when moving the table.

CHANGING MACHINE SPEED

- Turn the power off.
- To select the proper speed, move the speed lever to the desired position.
- If the gears are not engaged, remove the arbor bolt cover. Rotate the spindle slightly to engage the gears, then replace the arbor bolt cover.
- Recheck the lever setting, then turn the power on.

Lever RPM	I-L	I-M	I-H	II-L	II-M	II-H
50HZ	80	145	260	375	710	1250
60HZ	95	175	310	450	850	1500

INSTALLING AND CHANGING TOOLS

WARNING
BE SURE THE POWER IS TURNED OFF
AND THE MACHINE UNPLUGGED
BEFORE INSTALLING OR CHANGING
TOOL BITS.

- 1.Removing face mill or drill chuck arbor.**
Loosen the arbor bolt at the top of the spindle shaft approximately 2 turns with a wrench, rap the top of the arbor bolt with a mallet. After taper has been broken loose, holding chuck arbor on a hand and turn the arbor bolt with the other hand.
- 2. To install face mill or cutter arbor**
Insert cutter and cutter arbor into the taper of spindle. Tighten arbor bolt securely, but do not over tighten.
- 3. Removing taper drills**
 - Turn down the arbor bolt and insert the taper drill into the spindle shaft.
 - Turn down the rack sleeve until the oblong hole in the rack sleeve appears, lock the rack sleeve, insert wedge through holes and strike lightly with a mallet, this will force the taper drill out.

ORDERING REPLACEMENT PARTS

Complete parts list is attached, if parts are needed, contact your local distributor.

ADDITIONAL TOOLS AND ACCESSORIES YOU WILL FIND HELPING

Each of machine is equipped with a M.T.3 or R8 ,contact your local distributor or a main cutting tool distributor to obtain any of these accessories.
 Taper drill.Reamers, End mills,Cutter arbor, Taps,Collets,Adapters and sleeves.

SPECIFICATION OF THE T-SLOT

Please refer to figure, purchase or make T-bolts and other table top fixtures to these dimensions.

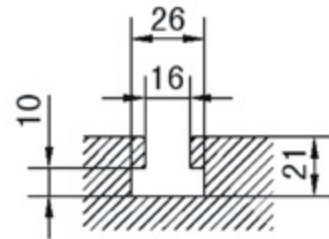

ELECTRICAL SYSTEM

WARNING:

A fuse must be connected between machine and power. The ground terminal of machine must be grounded properly. Don't open electrical box during operation, if something is wrong with machine, please ask repairman for help.

SPECIFICATIONS OF USE

Voltage	Phase	
	Single phase	Three phase
110V	30A	
220V	15A	7.5A
380V		5A

FOR AUTO-TAPPING ELECTRICAL SYSTEM

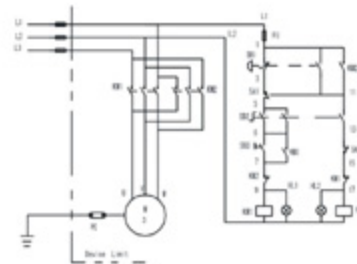

Three Phase

FOR COMBINATION SWITCH

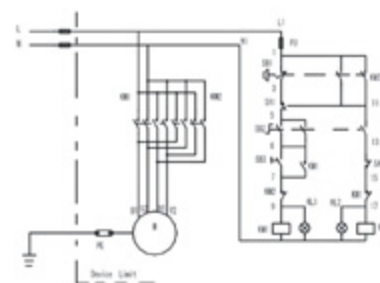
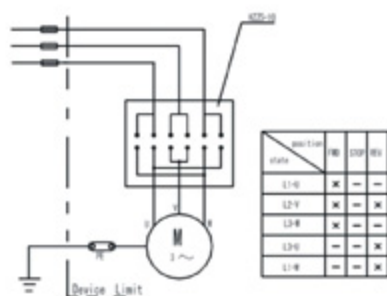
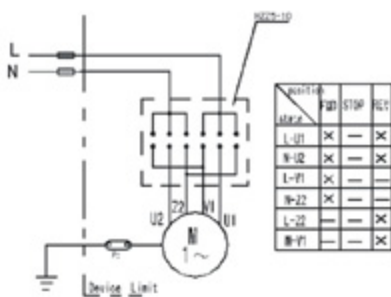

Single Phase

The standard wiring of the machine is single phase 220V/110V, 50HZ/60HZ or three phase 380V/220V, 50HZ/60HZ. For special request, please refer to the wiring diagram in the addendum.

TROUBLE SHOOTING

1.The machine doesn't run when the power switch is turned ON

- a). The knob is in the stop position
- b). A fuse has burned out
 - check in the switch box, and replaces it necessary.
- c). If there is a surge in the current, the circuit breaker may have opened
 - press the circuit breaker back, if it is in the open position.
- d). The gear may not be engaged
 - adjust the speed lever to be sure it is engaged.

2.The motor overheats, or there is insufficient power

- a).The machine is overloaded
 - Reduce the load of feed.
- b).The voltage supply is too low
 - provide with a reliable power supply.
- c).The switch may have a burned or broken contact point
 - Replace the switch.
- d).The contactor relay may be broken
 - Replace it.
- e).There may be a poor electrical connection. Have a qualified electrician check the wiring and power supply.
- f).The motor is poor
 - replace with new one.
- g).The drill bit or cutting blade may be worn
 - Sharpen or replace the bits as needed.

3.The spindle bearing is very hot

- a).There is insufficient lubrication
 - Turn off the power, and check the bearing for lubrication. If necessary, apply bearing grease.
- b).The spindle bearing is worn, or is fixed too tight
 - Turn off the power, unplug the electrical connection, and rotate the spindle by hand. Be sure it freely. If not, adjustment of the bearing .If you feel no use in the bearing, you will have to replace it.
- c).The spindle has been turning at high speed for a long time
 - After Long use, turn the machine off for a while to give it a rest, and allow it to cool off.

4.Table travel is not balanced

- a).The gap of the table guide is too wide or feel a heavy drag when moving the table
 - adjust gib strip in proper
- b).The locked bolts may be loose
 - check and tighten them if necessary.
- c).The feed is too deep
 - reduce the depth of cutting, make several passes to reach the required depth.

5.There is vibration, and roughness of working surface during performance.

- a).The gap of spindle bearing is too wide
 - adjust the gap in proper or replace bearing with new one.
- b).Spindle loosening up and down
 - check the adjustment of the two inner bearing covers. adjust them so there is no free play in the taper bearing, and the bearing turns freely. tighten them against each other to save this adjustment.
- c).The gap of the taper sliding plate is too wide
 - adjust the bolt tension.
- d).The chuck is loose
 - tighten the chuck.
- e).The drill bit or cutter is dull
 - sharpen or replace it. be sure to use cutting fluid to preserve tool life.
- f).The workpiece is not held firmly
 - check the clamps or vise you are using, and assure to tighten the workpiece

6.the micro feed does not work smoothly

- a).The clutch may be loose
 - check this and tighten if necessary.
- b).The worm or worm shaft may be worn
 - check these and replace if necessary
- c).The handwheel fixed screw may be loose
 - check it and tighten if necessary.

7.the workpiece is not machined accurately

- a).Imbalance of heavy workpiece
 - check to see that heavy workpiece are held in balance. the workpiece out of balance may shift when being machined
- b).A hammer has been used on the workpiece
 - never strike the workpiece with a hammer.
- c).The table may not be level
 - check the table with a level to be sure it is level both side to side and front to back.

- d).The machine may not be stable in the floor
–be sure the machine is firmly mounted to the floor.

MAINTENANCE

1.After each use

- a).Turn off the power switch.
- b).Remove any tool bits, clean and lubricate them, and return them to their storage case.
- c).Using a stiff bristle brush, brush off all chips.
- d).Using a rag, wipe off any excess or dirty oil or cutting fluid left on the machine.
- e).Lubricate the points, apply light grease or oil to all unpainted metal to prevent corrosion.
- f).Cover the machine to prevent dust or dirt contamination when not in use.

2.Daily maintenance

- a).Fill the oil reservoir to the proper level before each use
- b).Check the tightness of the bolts holding the head in place.
- c).If overheating or unusual noises are produced, stop the machine immediately

to check for lack of lubrication, faulty adjustments, dull tool bits or other deficiencies, correct any problems before resuming work.

- d).Keep the work area clean.

3.Weekly maintenance

- a).Clean and coat the lead screw with oil.
- b).Check the lubrication of the sliding parts of the table. apply light grease if needed.

4.Monthly maintenance

- a).Adjust the accuracy of the slides on both the cross and longitudinal feeding.
- b).Lubricate the bearings, worm gear and worm shaft with light grease.

5.Yearly maintenance

- a).Adjust the table to assure that it is level in all directions.
- b).Check the electrical cord, plug, circuit breakers and related connections to assure that they are secure and safe.

TABLE ASSEMBLY

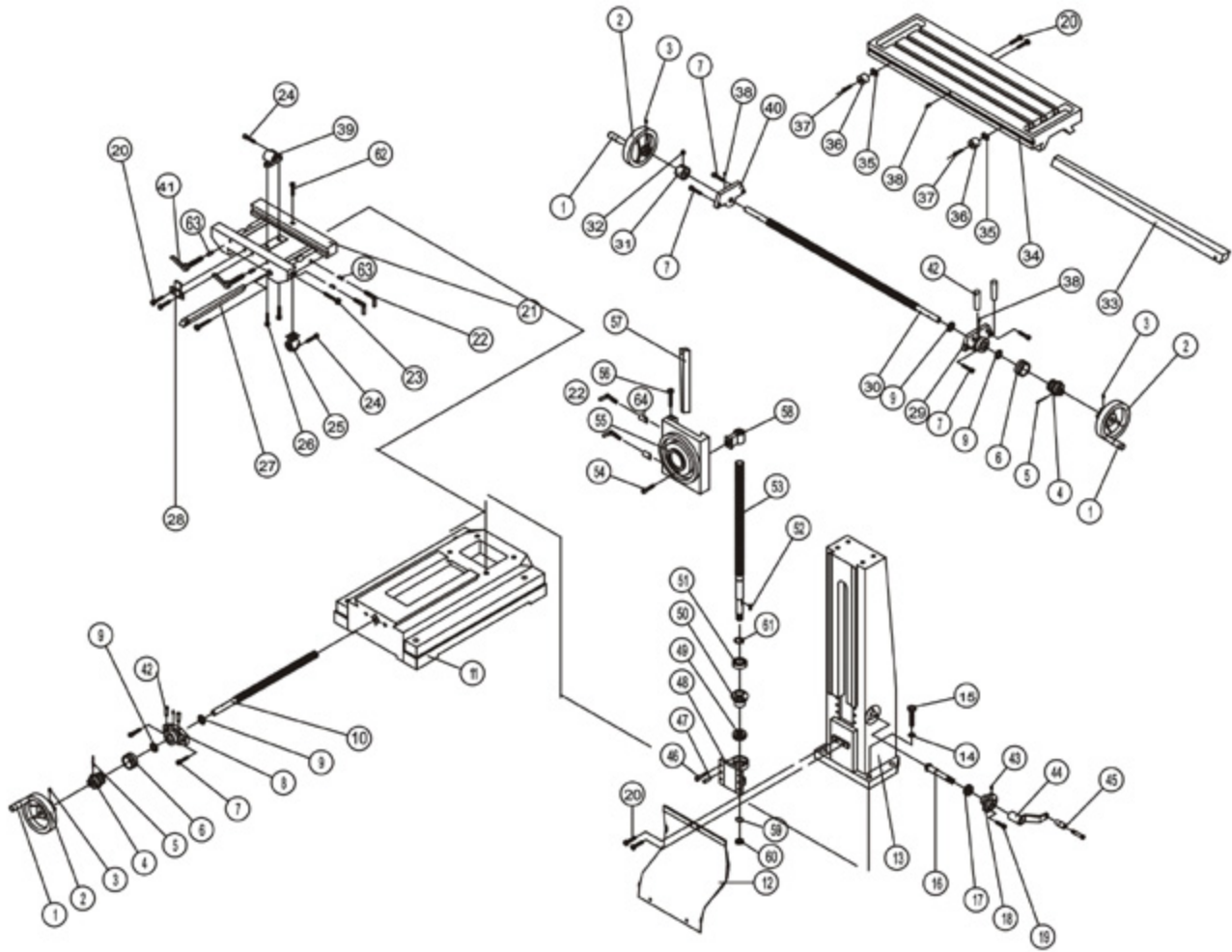

TABLE ASSEMBLY PART LIST

No.	PART NO.	Headstock Assembly	QTY
1	GB/T7270.4	Handle M10 × 80	3
2	ZX32-01-028	Handwheel	3
3	GB/T77-85	Screw M6 × 10	3
4	ZX32-01-023	Dial Clutch	2
5	GB/T879-86	Spring Pin 5 × 40	2
6	ZX32-01-022	Dial Ring	2
7	GB/T70-85	Screw M8 × 16	6
8	ZX32-01-027	Square Flange C	1
9	GB/T301-94	Thrust Bearing 51103	4
10	ZX32-01-024	Cross Lead Screw	1
11	ZX32-01-016	Base	1
12	ZX32-01-010	Anti-dust Plate	1
13	ZX32W-01-004	Square Column	1
14	GB/T-93-87	Spring Washer 16	4
15	GB/T5780-86	Bolt M16 × 60	4

TABLE ASSEMBLY PART LIST

Index No.	Part No.	Description	QTY.
16	ZX32W-01-008	Tap Gear Shaft	1
17	GB/T301-94	Thrust Bearing 511	1
18	ZX32W-01-009	Seat	1
19	GB/T70-85	Screw M6 x 20	3
20	GB/T5781-86	Bolt M8 x 12	2
21	ZX32-01-015	Middle Base	1
22	ZX32-01-020	Lock Screw	4
23	ZX32-01-004	Set Screw	2
24	GB/T70-85	Screw M5 x 14	1
25	ZX32-01-025	Cross Nut	1
26	GB/T70-85	Screw M8 x 16	2
27	ZX32-01-019	Gib (short)	1
28	ZX32-01-005	Fixed Block	1
29	ZX32-01-002	Square Flange A	1
30	ZX32-01-021	Longitudinal Lead Screw	1
31	ZX32-01-014	Dial Clutch	1
32	GB/T77-85	Screw M10 x 10	1
33	ZX32-01-003	Gib (long)	1
34	ZX32-01-001	Table	1
35	ZX32-01-012	Moveable Fixed Block	2
36	ZX32-01-011	Moveable Fixed Ring	2
37	GB/T70-85	Screw M6 x 12	2
38	JB/T7940.1	Oil Cup	5
39	ZX32-01-026	Longitudinal Nut	1
40	ZX32-01-013	Square Flange B	1
41	JB/T7270.12-94	Adjusted Set Handle Bm10 x 32	2
42	GB/T118-86	Taper Pin 8 x 30	4
43	GB/T1155-79	Oiler 6	1
44	ZX32W-01-018	Crank	1
45	GB/T7270.1-94	Handle 6 x 63 x 12	1
46	GB/T118-86	Taper Pin 8 x 30	2
47	GB/T70-85	Lock Screw M8 x 20	4
48	ZX32W-01-006	Bracket	1
49	GB/T301-95	Bearing 51103	1
50	ZX32W-01-007	Taper Gear	1
51	GB/T276-94	Bearing 6204-2rs	1
52	GB/T1096-79	Key 5 x 12	1
53	ZX32W-01-005	Lead Screw	1
54	GB/T70-85	Screw M8 x 40	1
55	ZX32W-01-001	Connective Base	1
56	ZX32W-01-014	Adjustable Screw	1
57	ZX32W-01-003	Gib	1
58	ZX32W01-002	Lead Nut	1
59	GB/T858-76	Stop Washer	1
60	GB/T810-88	Nut M16 x 1.5	1
61	GB/T894.1-86	Retain Ring (external) 20	1
62	GB/T70-85	Screw M8 x 45	1
63	HQ400-11-015	Clamping Incline Block	4
64	ZX32W-01-013	Clamping Incline Block	2

HEADSTOCK ASSEMBLY

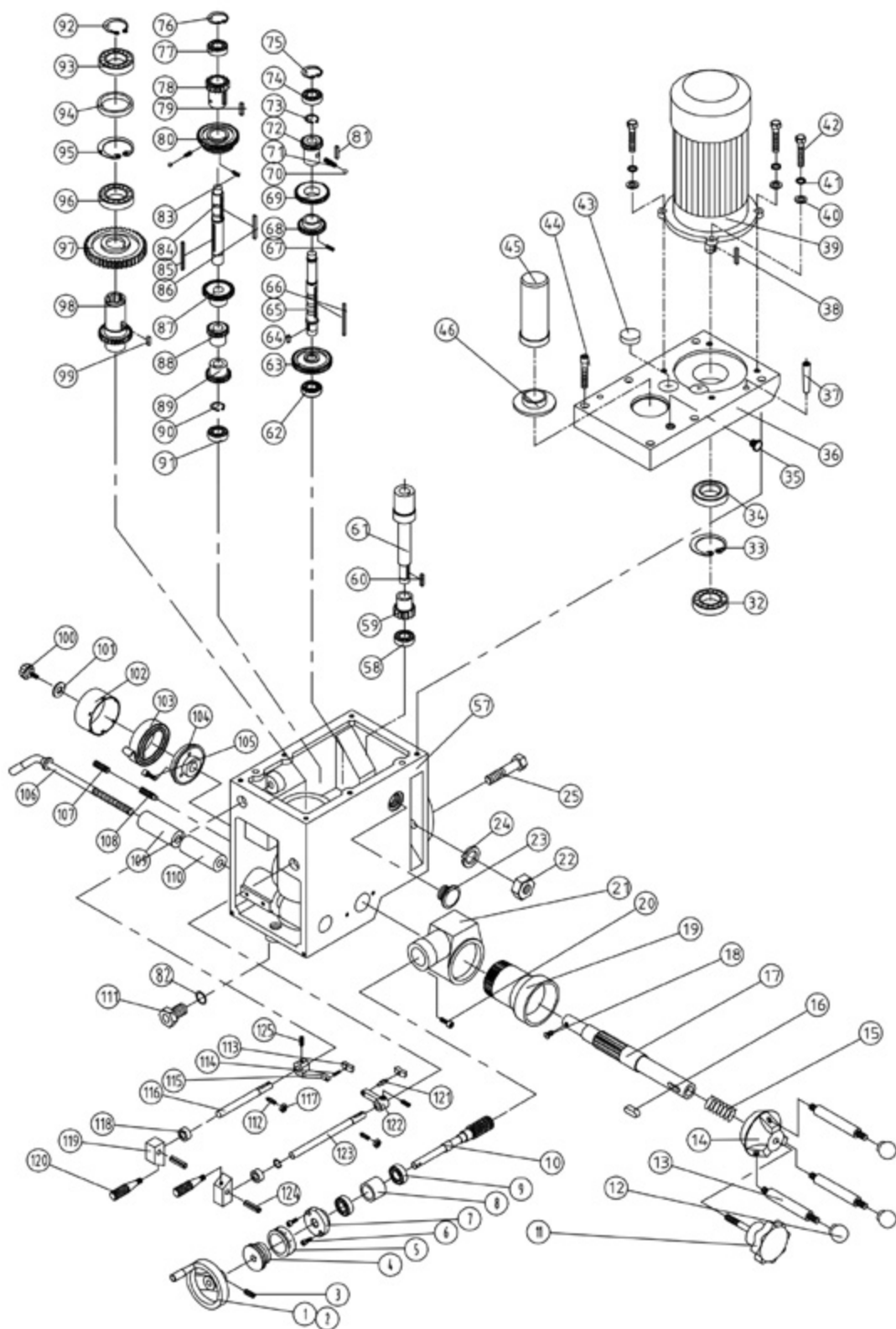

HEADSTOCK ASSEMBLY PART LIST

No.	PART NO.	Headstock Assembly	QTY
1	JB/T7273.2	Handwheel 12x100	1
2	JB/T7270.4	Handle M6x32	1
3	GB/T77-85	Screw M8x10	1
4	ZX32-05-002	Dial Seat	1
5	ZX32-01-022	Dial Ring	1
6	GB/T70-85	Screw M5x15	6
7	ZX32G-04-009	Cover	1
8	ZX32G-04-008	Bearing Spacer	1
9	GB/T276-94	Bearing 6202	2
10	ZX32G-04-007	Worm Shaft	1
11	ZX32G-04-006	Lock Bolt With Knob	1
12	JB/T7271.1-94	Knob	3
13	JB/T7271.6-94	Knob Rod	3
14	ZX32G-04-004	Spring Base	1
15	ZX32G-04-005	Spring	1
16	GB/T1096	Key 8x22	1
17	ZX32G-04-001	Gear Shaft	1
18	GB/T818-85	Screw M4x8	1
19	ZX32G-04-003	Worm	1
20	GB/T70-85	Screw M8x20	2
21	ZX32G-04-002	Feed Cover	1
22	GB/T6182-86	Lock Nut M16	2
23	GB/T1160.2-89	Fluid Lever Indicator	1
24	GB/T93-87	Spring Washer	2
25	GB/T5782-86	Bolt M16x60	2
32	GB/T276-94	Bearing 6007	3
33	GB/T893.2-86	Inner Ring B62	2
35	ZX32G-02-037	Nameplate	1
34	GB/T9877.1	Oil Seal	1
36	ZX32G-02-011	Head Body Cover	1
37	GB/T118-86	Taper Pin 10x50	2
38	GB/T1096	Key 6x35	1
39		Motor	1
40	GB/T95-85	Washer 10	4
41	GB/T93-85	Spring Washer 10	4
42	GB/T5782-86	Bolt M10x35	4
43	ZX32G-02-015	Cap	2
44	GB/T70-85	Screw M8x55	6
45	HQ400-24-021	Arbor Bolt Cover	1
46	ZX32G-02-013	Arbor Bolt Cover Base	1
47	GB/T77-85	Screw M10x8	1
48	ZX32G-02-046	Crank	1
49	JB/T7270.4-94	Handle M10x50	1
50	GB/T70-85	Screw M6x10	4
51	ZX32G-02-045	Airflow Plug	1
52	ZX32G-02-032	Bracket	1
53	ZX32G-02-036	Shaft	1
54	ZX32G-02-033	Set Washer	1
55	ZX32G-02-035	Worm	1

HEADSTOCK ASSEMBLY PART LIST (CONT.)

No.	PART NO.	Headstock Assembly	QTY
56	ZX32G-02-034	Worm Shaft	1
57	ZX32G-02-001	Headstock	1
58	GB/T276-94	Bearing 6003	3
59	ZX32G-02-023(2)	Gear Shaft	1
60	GB/T1096	Key 6x32	1
61	ZX32G-02-023(1)	Bushing	1
62	GB/T276-94	Bearing 6003	1
63	ZX32G-02-024	Gear	1
64	GB/T1096	Key 6x12	1
65	ZX32G-02-017	Shaft	1
66	GB/T1096	Key 5x60	1
67	GB/T73-85	Screw M5x8	1
68	ZX32G-02-020	Gear	1
69	ZX32G-02-019	Gear	1
70	GB/T308-84	Steel Ball 8	2
71	GB/T2089-84	Spring	2
72	ZX32G-02-018	Gear	1
73	GB/T894.1-94	Retainer Ring (external)18	2
74	GB/T276-94	Bearing 6202	3
75	GB/T893.2	Retainer Ring (internal) B35	1
76	GB/T893.2	Retainer Ring (internal) B35	1
77	GB/T276-94	Bearing 6202	1
78	ZX32G-02-016	Gear	1
79	GB/T1096	Key 6x15	1
80	ZX32G-02-014	Gear	1
81	GB/T1096	Key 6x28	1
82	GB/T3452.1-82	Gasket Ring 9.8x2.65	1
83	GB/T73-85	Screw M5x8	1
84	ZX32G-02-003	Shaft	1
85	GB/T1096	Key 6x75	1
86	GB/T1096	Key 5x50	1
87	ZX32G-02-006	Gear	1
88	ZX32G-02-005	Gear	1
89	ZX32G-02-004	Gear	1
90	GB/T894.1-86	Inner Ring 18	1
91	GB/T276-94	Bearing 6202	1
92	GB/T894.2	Retain Ring (external) 35	1
93	GB/T276-94	Bearing 6007	1
94	ZX32G-02-012	Spacer	1
95	GB/T893.2-86	Retainer Ring (internal) B62	1
96	GB/T276-94	Bearing 6007	1
97	ZX32G-02-010	Gear	1
98	ZX32G-02-009	Spline Sleeve Gea.	1
99	GB/T1096	Key 6x18	1
100	ZX32G-02-041	Screw Knob	1
101	ZX32G-02-042	Washer	1
102	ZX32G-02-043	Spring Cover	1
103	ZX32G-02-047	Spring	1
104	ZX32G-02-040	Spring Base	1

HEADSTOCK ASSEMBLY PART LIST (CONT.)

No.	PART NO.	Headstock Assembly	QTY
105	GB/T70-85	Screw M5x10	3
106	ZX32G-02-039	Lock Handle	1
107	GB/T77-85	Screw M10x20	1
108	GB/T79-85	Screw M10x25	1
109	ZX32G-02-038	Fixed Tight Collar A	1
110	ZX32G-02-038	Fixed Tight Collar B	1
111	ZX32G-02-002	Oil Drainer Plug	1
112	GB/T73-85	Screw M6x10	2
113	ZX32G-02-025	Fork Block	2
114	GB/T879-86	Spring Pin 4x12	1
115	ZX32G-02-030	Fork	1
116	ZX32G-02-028B	Lever Shaft (short)	1
117	GB/T41	Nut M6	2
118	GB/T9877.1	Oil Seal B12x22x 7	2
119	ZX32G-02-029A	Handle Base	2
120	ZX32G-02-029B	Handle	2
121	ZX32G-02-026	Pin Shaft	1
122	ZX32G-02-027	Fork	1
123	ZX32G-02-028A	Lever Shaft (long)	1
124	GB/T9877.1-88	Spring Pin 4x25	2
125	GB/T822-85	Screw M5x20	2
126	JB/T7270.4	Handle Taper M8X32	2

SPINDLE ASSEMBLY

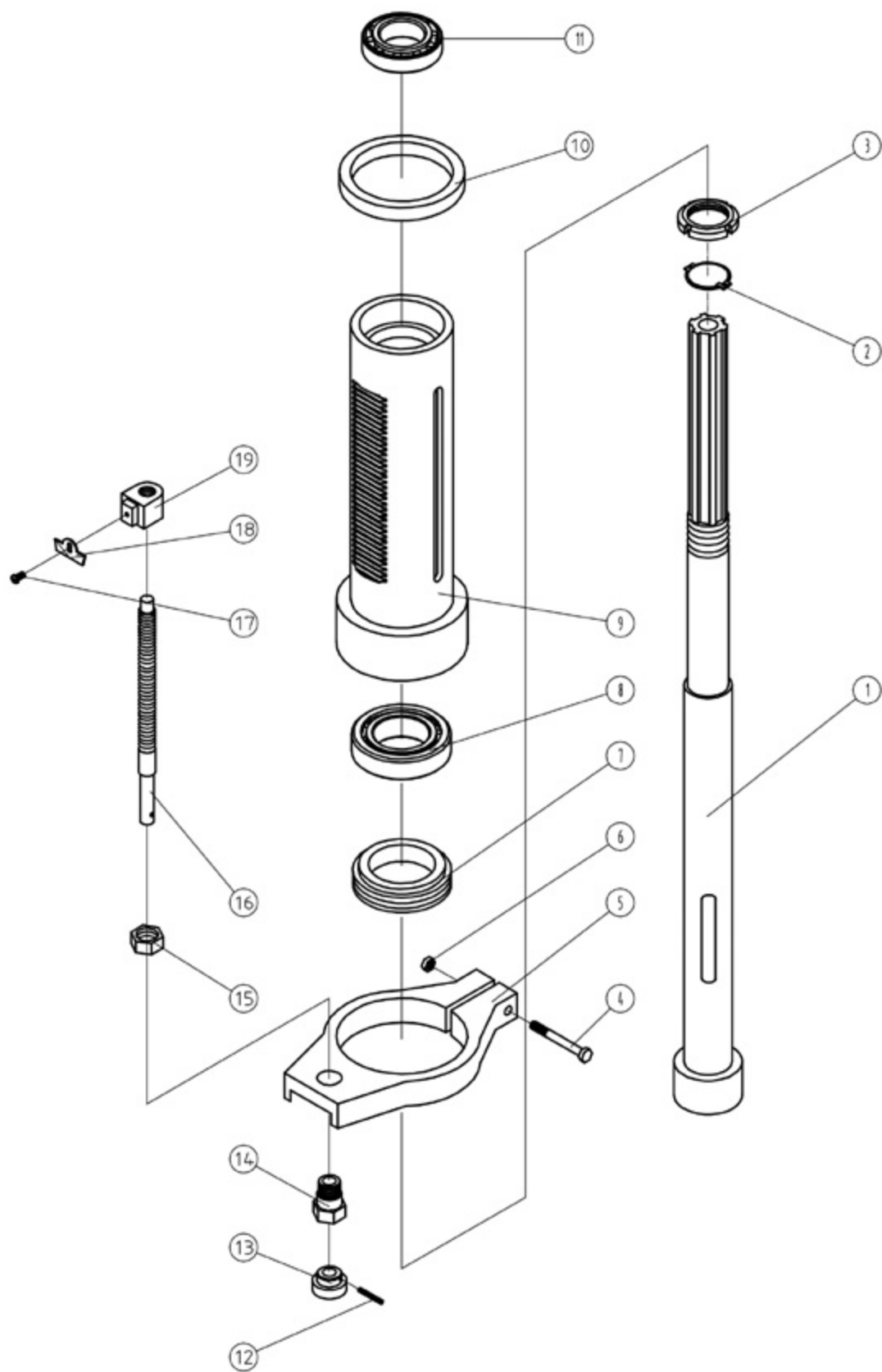

SPINDLE ASSEMBLY PART LIST

No.	PART NO.	Headstock Assembly	QTY
1	ZX32G-03-001	Spindle	1
2	GB/T858-88	Stop washer 30	1
3	GB/T810-86	Nut M30x1.5	1
4	GB/T5780-86	Bolt M6x50	1
5	ZX32G-03-003	Graduate rod base	1
6	GB/T41-86	Nut M6	1
7	ZX32G-03-002	Anti-dust ring	1
8	GB/T297-94	Bearing 30207/P6	1
9	ZX32G-03-005	Rack sleeve	1
10	ZX32G-03-004	Rubber flange	1
11	GB/T297-94	Bearing 30206/P6	1
12	GB/T879-86	Spring pin 3x18	1
13	ZX32G-03-010	Handle	1
14	ZX32G-03-009	Support	1
15	GB/T6172-86	Thin nut M16	1
16	ZX32G-03-006	Graduate rod	1
17	GB/T818-85	Screw M4x6	1
18	ZX32G-03-008	Indicating plate	1
19	ZX32G-03-007	Set position block	1



OTMT