



*Swivel 3-1/2" Metal Cutting
Band Saw*

Swivel 3-1/2" Metal Cutting Band Saw



**Before Operating Your Tools,
Please Read This Instruction Carefully**

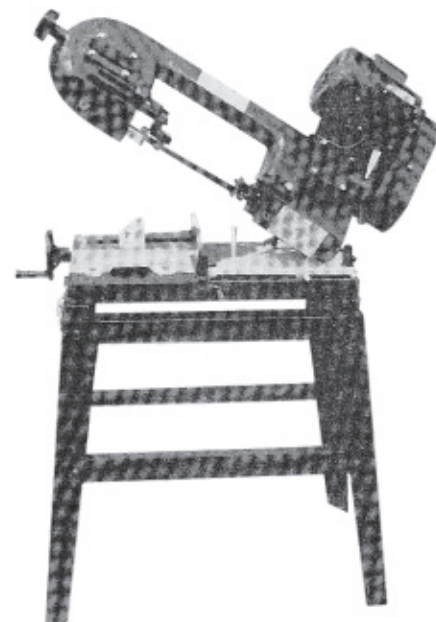

**Item No.87-115-631
Model No. T409**

SAFETY PRECAUTIONS

1. Know Your Machine Tool

Read and understand the owner's manual and labels affixed on the tool. Learn its application and limitations as well as the specific potential hazards peculiarly to this tool.

2. Keep Guards In Place

And in working order.

3. Remove Adjusting Keys And Wrenches

Form a habit of checking to see that keys and adjusting wrenches are removed from the saw before turning it on.

4. Keep Work Area Clean

Cluttered areas and benches invite accidents. Floor must not be slippery due to oil or sawdust.

5. Avoid Dangerous Environment

Do not use power tools in damp or wet locations or expose them to rain. Keep work area well lit. Provide adequate surrounding work space.

6. Keep Children Away

All visitors should be kept at a safe distance from working area.

7. Make Workshop Childproof

With padlocks, master switches, or by removing starter keys.

8. Do Not Force tool

It will do the job better and safer at the rate for which it was designed.

9. Use Right Tool

Do not force tool or attachment to do a job for which it was not designed.

10. Wear Proper Clothing

Do not wear loose clothing, gloves, necklace or jewellery (rings, wristwatches) to catch in moving parts. NON SLIP footwear is recommended. Wear protective hair covering to contain long hair. Roll long sleeves above the elbow.

11. Use Safety Goggles(head Protection)

Wear safety goggles (must comply with BS2092) at all times. Normal spectacles only have impact resistant lenses, they are NOT safety glasses. Also, use face or dust mask if cutting operation is dusty and ear protectors (plugs or muffs) during extended periods of operation.

12. Secure Work

Use clamps or a vice where applicable to hold work. This frees both hands to operate the machine.

13. Do Not Overreach

Keep proper footing and balance at all times.

14. Maintain Tools With Care

Keep tools sharp and clean for best and safest performance. Follow instructions for lubricating and changing accessories.

15. Disconnect Power To The Tools

Before servicing, when changing accessories such as cutters etc.

16. Avoid Accidental Starting

Make sure switch is in OFF position before plugging in cable to the power supply.

17. Use Recommended Accessories

Consult the owner's manual for recommended accessories. Follow the instructions that accompany the accessories. The use of improper accessories may cause hazards.

18. Never Stand On Tool

Serious injury could occur if the tool is tipped or if the cutting tool is accidentally contacted.

Do not store materials above or near the tool such that it is necessary to stand on the tool to reach them.

19. Check Damaged Parts

Before further use of the tool, a guard or other part that is damaged should be carefully checked to ensure that it will operate properly and perform its intended function. Check for alignment of moving parts, breakage of parts, mounting and any other conditions that may affect its operation. A guard or other part that is damaged should be properly repaired or replaced.

20. Direction Of Feed

Feed work into a blade or cutter against the direction of rotation of the blade or cutter only.

21. Never Leave Machine Running Unattended

Turn power off. Do not leave machine until it comes to a complete stop.

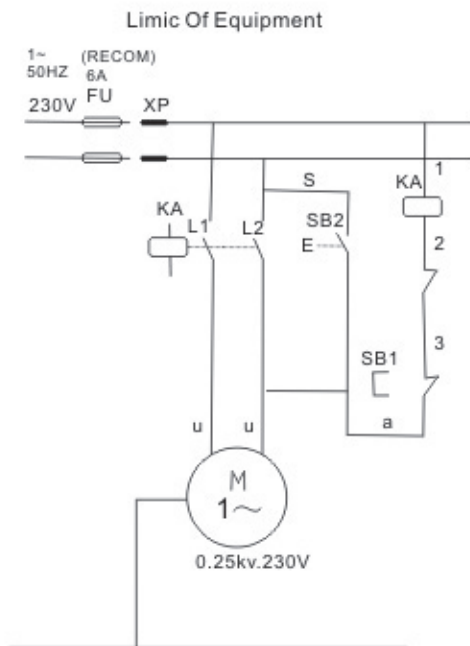

ELECTRICAL PART LIST

Item	Description	Description and fuarton	Technic Data
KA		Coauctor - relay	Coil:210Vac Current:10A
SB1 SB2		Push burton OFF:1<>red ON:1<<a>>green	IP 54:250 Vac IP 54:250 Vac
XB		Teroniozl block	AC 380V : MAX 10A
		Supply Cable	AC 600V. 10A. 3G/0.75mm >for 0.375 motor AC 600V. 10A. 3G/1.00mm >for 0.55 KW motor
M		Motor	0.375 KW/230V.IP 54 0.55 KW/230V.IP 54

◆ MACHINE ADJUSTMENTS

● Tracking The Blade

1. First disconnect machine from power supply.
2. Open blade guard.
3. Loosen blade tension by turning blade tension knob.
4. Loosen grub screw I Fig.3. This will enable the motor pulley J Fig.3 to be adjusted whilst on the shaft.
5. When pulley wheel is adjusted re-tighten grub screw I.
6. Replace tension on the blade using blade tension knob and close blade guard.

● 7. Reconnect power supply.

Blade Guide Bearing Adjustment

It is impossible to get satisfactory work from the saw if the blade guides are not properly adjusted.

1. Disconnect machine from power supply.
2. Loosen Hex. nut K Fig.4.
3. Adjust bearings L Fig.4 until they just touch the blade (Approx.0.001").
4. Retighten hex. Nut K.
5. Reconnect power supply.

Blade Guide Adjustment

There are two blade guides, one each side of the workpiece.

1. Disconnect machine from power supply.
2. First loosen hex. Bolt M Fig.5.
3. Pivot blade adjustment bracket N until blade is square with machine bed.
4. Retighten hex. Bolt M.
5. Reconnect power supply.

Note: -Blade guide assembly can be adjusted by un-clamping adjustment knob G Fig.2.

◆ MAINTENANCE

1. Clean the band saw after each operation.
2. Coat the machine with rust-proof oil.
3. Use a standard grade oil to lubricate the bandsaw's components. SAE-30 oil is recommended for this purpose.

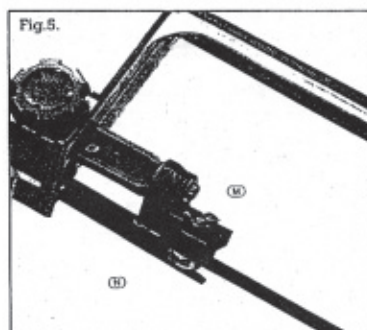
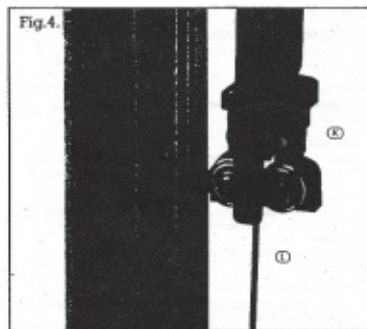
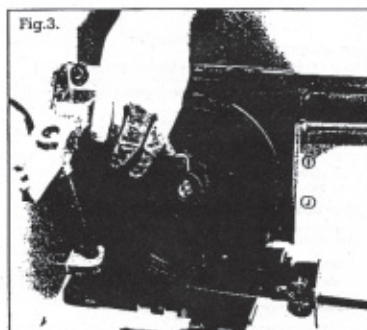

TROUBLESHOOTING

SYMPTOM	POSSIBLE CAUSES	CORRECTIVE ACTION
Excessive Blade Breakage	<ol style="list-style-type: none"> 1. Material is loose in vice 2. Incorrect speed or feed 3. Blade teeth spacing is too large 4. Material is too course 5. Incorrect blade tension 6. Blade is in contact with material before saw is started 7. Blade rubs on wheel flange 8. Misaligned guide pivots 9. Blade is too thick 	<ol style="list-style-type: none"> 1. Clamp work securely 2. Adjust speed or feed 3. Replace with smaller TPI blade 4. Use blade at slower speed and smaller TPI 5. Adjust tension so blade does not slip on the wheel 6. Place blade in contact with work only after the motor has started. 7. Adjust wheel alignment 8. Adjust guide pivots 9. Use thinner blade
Premature Blade Dulling	<ol style="list-style-type: none"> 1. Blade teeth are too course 2. Too much speed 3. Inadequate feed pressure 4. Hard spots or scale on material 5. Blade is twisting 6. Insufficient blade tension 7. Blade is sliding 	<ol style="list-style-type: none"> 1. Use smaller TPI blade 2. Reduce speed 3. ADJUST SPRING 4. REDUCE SPEED, INCREASE FEED PRESSURE 5. Replace blade, adjust blade tension 6. Tighten blade tension 7. Tighten blade tension, reduce speed
Unusual Wear on Side or Back of Blade	<ol style="list-style-type: none"> 1. Blade guides are worn 2. Blade guide pivots are misaligned 3. Blade guide brackets are loose 	<ol style="list-style-type: none"> 1. Replace blade guides 2. Adjust guide pivots 3. Tighten blade guide brackets
Teeth Ripping from Blade	<ol style="list-style-type: none"> 1. Blade is too course for the work 2. Too much pressure, speed is too slow 3. Workpiece is vibrating 4. Blade is too fine for the work 	<ol style="list-style-type: none"> 1. Use a finer TPI blade 2. Decrease pressure and increase speed 3. Clamp work more securely 4. Use a courser TPI blade
Motor Overheating	<ol style="list-style-type: none"> 1. Blade tension is too high 2. Drive belt tension is too high 3. Blade is too course 4. Blade is too fine 5. Gears need lubrication 6. Cut is binding blade 	<ol style="list-style-type: none"> 1. Reduce blade tension 2. Reduce drive belt tension 3. Use smaller TPI blade 4. Use courser TPI blade 5. Lubricate gears 6. Decrease feed and speed
Bad, Crooked or Rough Cuts	<ol style="list-style-type: none"> 1. Feed pressure is too great 2. Guide pivots are misaligned 3. Inadequate blade tension 4. Blade is dull 5. Incorrect speed 6. Blade guides are spaced out too much 7. Blade guide assembly is loose 8. Blade is too course 	<ol style="list-style-type: none"> 1. Adjust spring to reduce pressure 2. Adjust guide pivots 3. Increase blade tension 4. Replace blade 5. Adjust speed 6. Adjust guide spacing 7. Tighten guide assembly 8. Use a finer TPI blade
Blade is Twisting	<ol style="list-style-type: none"> 1. Cut is binding blade 2. Blade tension is too high 	<ol style="list-style-type: none"> 1. Decrease feed pressure 2. Decrease blade tension

◆ ELECTRICAL CONNECTION & OPERATION

ELECTRICAL CONNECTION:

1. This metal cutting band saw is equipped with a standard plug to connect to the power source with single phase.50Hz, and 220V or 240V.
2. For the protection of control device, we recommend the operator to supply a fuse with 6 A current of fuse.
3. The total length between supply fuse and plugsocket connection shall not greater than 1.5m .

ELECTRICAL DISCONNECTION:

1. The disconnection of metal cutting band saw is carried out by removing plug from socket.
2. Be sure to disconnect this machine from power source, when you want to stop the job and maintain or inspect this machine.

GROUNDING:

1. The grounding system of this machine is provided in the way of standard plug which is in compliance with local standard.
2. **WARNING!** "Do not change the plug into any type other than we provide."

OPERATION:

1. **START:** Push the button marked with "1".
2. **STOP:** Push the button marked with "0".
3. **STOP AT THE END OF CUTTING:** This machine will stop automatically at the end of cutting.

INTERLOCK FOR PULLEY COVER: (OPTIONAL)

1. For the safety of changing speed, the interlock switch (SQ) is provided as an optional device of control device.
2. If your machine is equipped with interlock switch, do not sure this device to stop machine in normal operation.

INSTALLATION & ADJUSTMENTS

INSTALLATION:

1. Before installation, sufficient space with at least 2.5m * 2.5m, by a free space of at least 0.8m all directions shall be provided for the machine.
2. The place, provided for the machine, should be clean and flat enough.
3. Sufficient lighting should be provided according to the local regulation for metal working or at least 300 Lux ambient lighting intensity if no local regulations exist.

ADJUSTMENTS:

Adjustments of saw blade

1. The adjustment of saw blade is carried out by the blade tension knob with the indicator.
2. Suitable blade tension is adjusted by hand without the help of tool. For a suitable blade tension, it can not be move by the test of finger with appropriate force at saw blade.

Adjustments of blade cover (Left & Right)

The left and right adjustable blade cover are designed to prevent access to the moving saw blade during cutting. They must be adjusted as near as possible to the workpiece.

Part list for 3.1/2"Metal saw

Model no.:G409

Part List

PART	DESCRIPTION
1	Base
2	Bolt
3	Chain
4	Pad
5	Washer
6	Bolt
7	Nut
8	Bolt
9	Bolt

PART	DESCRIPTION
10	Bolt
11	Washer
12	Bolt
13	Turning bracket
14	Nut
15	Handle
16	Spring
17	Nut
18	Plate

PART	DESCRIPTION
19	Bolt
20	Axle
21	Shaft
22	Scale label
23	Bolt
24	Washer
25	Pointer
26	Washer
27	Hex bolt
28	Wheel handle
29	Washer
30	Bolt
31	Plate
32	Bolt
33	Plate
34	Washer
35	Spring washer
36	Vice
37	Threaded shaft
38	Knob
39	Bol
40	Bracket
41	Plate
42	Bracket
43	Bracket
44	Locking handle
45	Knob
46	Bolt
47	Washer
48	Washer
49	Bracket
50	Plate
51	Sealing washer
52	Gear
53	Bolt
54	Bolt
55	Bracket
56	Brackett

PART	DESCRIPTION
57	Bearing
58	Sleeve
59	Washer
60	Knob
61	Bolt
62	Axle
63	Wheel
64	Retaining ring
65	Bolt
66	Bracket
67	Plate
68	Pin
69	Blade
70	Knob
71	Cover
72	Screw
73	Wheel
74	Shaft
75	Washer
76	Key
77	Main body
78	Gear box
79	Pulley
80	Bearing
81	Shaft
82	Sealing plate
83	Pulley
85	Sleeve
86	V-belt
87	Pulley
88	Washer
89	Screw
90	Pulley cover
91	Key
92	Motor
93	Adjusting knob
94	Base
95	Bolt
101-107	Assembly

