

INSTRUCTION MANUAL

S4 , S4S , S4SV



**KALAMAZOO
INDUSTRIES, INC.**

6856 East K Avenue
Kalamazoo, MI 49048

269-382-2050 PH

269-382-0790 FAX

www.kalamazooindustries.com

WARRANTY

All products are guaranteed for a period of one year to the original purchaser, against defects in material workmanship under normal use. Electric motors are warranted by the motor manufacturer and will be repaired by the nearest motor repair station. If non-repairable, they will be replaced by Kalamazoo Industries. Please call for instructions 269-382-2050.

RETURN POLICY

Authorization must be obtained before returning merchandise. Please call our customer service department for a return authorization number at 269-382-2050. Please include with your return a copy of your invoice or packing slip. Materials must be sent back prepaid. (Unless otherwise indicated). All returns will be subject to a 10% restocking charge. No returns will be accepted after one year of invoice date.

BELT SANDER SAFETY

- READ THE OPERATING INSTRUCTIONS BEFORE RUNNING MACHINE.
- ALWAYS WEAR SAFETY GLASSES OR A FULL FACE SHIELD FOR PROTECTION.
- KEEPS HANDS CLEAR OF THE SANDING AREA.
- NEVER WEAR GLOVES OR LOOSE FITTING CLOTHES WHEN OPERATING THIS MACHINE.
- ALWAYS KEEP HAIR TIED BACK OR COVERED.
- LET MACHINE ROTATION COME TO A FULL STOP BEFORE CHANGING BELT.
- KEEP SAFETY GUARDS IN PLACE. DO NOT ALTER GUARDS OR MACHINE IN ANY WAY. ANY ALTERATIONS TO GUARDS OR MACHINE COULD CAUSE SERIOUS INJURY.
- ALL BELT SANDERS SHOULD BE OPERATED IN A WELL-VENTILATED AREA. THE DUST CREATED WHEN SOME MATERIALS ARE SANDED CAN BE HARMFUL. DUST MASKS ARE RECOMMENDED AS A PRACTICAL MEANS OF MINIMIZING DUST INHALATION. FUMES FROM OTHER SOURCES CAN ALSO CAUSE FIRES WHEN IN CONTACT WITH SANDING SPARKS.
- SPARKS CREATED BY SANDING SHOULD BE DIRECTED DOWNWARD AND AWAY FROM THE FACE AND BODY. DO NOT GRIND NEAR FLAMMABLE MATERIAL.
- ELECTRIC SANDING MACHINES ARE NOT INTENDED FOR USE IN OR NEAR WATER. THIS INCLUDES AN OPERATOR STANDING ON A WET FLOOR OR WORKING AROUND CONTAINERS OF WATER OR OTHER CONDUCTIVE LIQUIDS.

KALAMAZOO INDUSTRIES, INC.
6856 East K Avenue
Kalamazoo, MI 49048
269-382-2050 PH
269-382-0790 FAX
www.kalamazooindustries.com



Made in USA

WARNING!
TO REDUCE THE RISK OF FIRE OR SHOCK HAZARD,
DO NOT EXPOSE THIS EQUIPMENT TO RAIN, ANY LIQUID OR MOISTURE.

INSPECTION

If these goods are damaged in transit, the DELIVERING TRANSPORTATION COMPANY is required by law to make notation of damages on the freight bill. If in your opinion, there may be concealed damage, they are required to make an inspection after goods are unpacked. Transportation rates are made in proportion to damage. Therefore, the carrier and NOT the shipper should be charged with any loss or damage. Any claim should be filed with the delivering Transportation Company. PLEASE DO NOT RETURN GOODS TO US WITHOUT OUR RGA NUMBER AND SHIPPING INSTRUCTIONS. See back page for Return Policy and Warranty.

Read Operating Instructions and Precautions before using this equipment

OPERATING INSTRUCTIONS

1. Disconnect power before making any adjustments.
2. Abrasive belt rotation is counter-clockwise. If the abrasive belt is lap spliced be sure of correct rotation. Butt spliced belts are bi-directional.
3. Belt tension is pre-set with internal spring (17) No belt tension adjustment is needed.

4. **Belt Changing-** Disconnect power, squeeze belt manually, align flip cam to hold tension spring closed (A), remove belt and install new belt, move flip cam back to position (B) to tension belt.

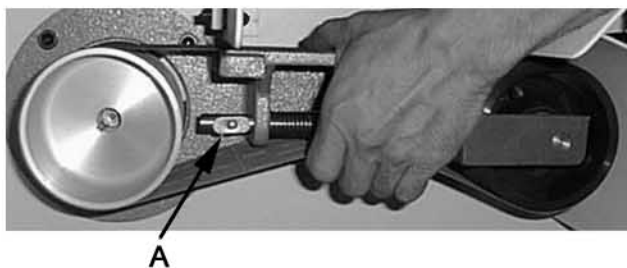

5. **Belt Tracking-** Tracking screw (11) twists yoke to center belt. With power OFF spin belt manually to verify belt tracking, adjust tracking screw to center belt, tighten jam nut to lock tracking screw. Jog belt with power ON to check belt centering or "tracking".



6. Always keep the work table within 1/8" of sanding belt. This will avoid pinching material between sanding belt and platen.
7. Examine the abrasive belt carefully before use. Never use an abrasive belt with a nicked or cut edge, crease or handling damage.
8. If you are using a dust collector, bags should be emptied frequently during use to maintain efficiency and prevent buildup of combustible materials.

PRECAUTIONS

1. Always wear safety glasses.
2. Keep long hair tied back or covered and never wear loose fitting clothing near a running machine.
3. Additional precautions may be necessary when grinding materials that are flammable or have other hazardous properties. Consult manufacturer of materials for safe grinding and handling.

KALAMAZOO INDUSTRIES, INC. 6856 East K Ave. Kalamazoo, MI 49048
269-382-2050 PH 269-382-0790 FAX www.kalamazooindustries.com

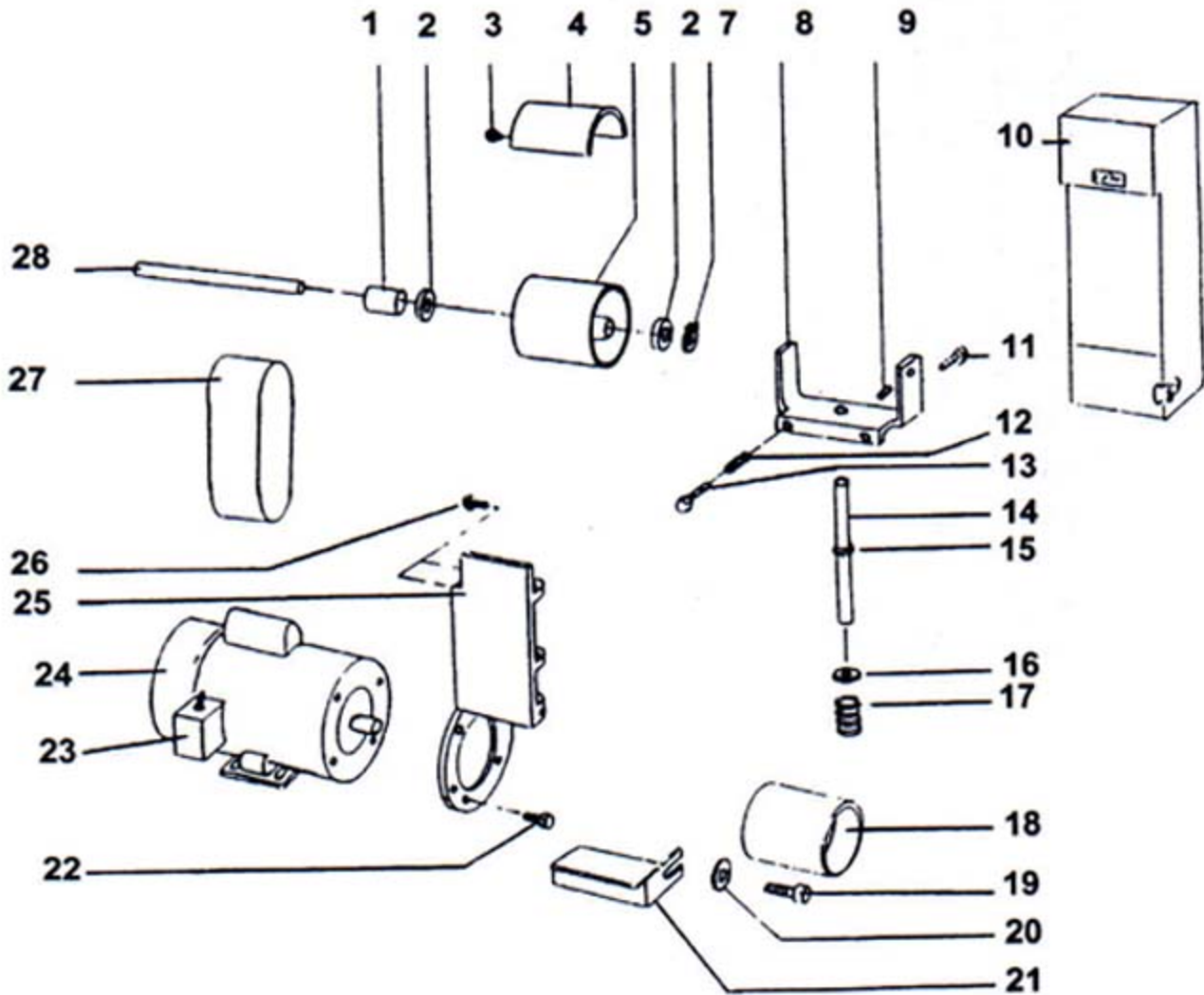

ITEM# PART NO DESCRIPTION QTY

1	123-003	COLLAR	1
2	044-002	BEARINGS (IN IDLER PULLEY)	2
3		1/2-20x1/2 R.H.M.S.	2
4	342-005	UMBRELLA GUARD	1
5	560-006	IDLER PULLEY W/BEARINGS	1
7	5100-50	RETAINING RING	1
8	960-002	YOKE	1
9		10-24x3/8 S.S.C.	1
10	342-022	OSHA GUARD	1
11		TRACKING SCREW	1
12	697-011	SPRING	1
13		10-24x1-1/2 F.H.	1
14	700-001	SHAFT	1
15		1/2" SNAP RING	1

16		1/2" WASHER	1
17	697-010	TENSION SPRING	1
18	560-005	DRIVE WHEEL	1
19		5/16-18x3/4 H.H.C.S.	1
20		5/16" WASHER	1
21	829-004	WORK TABLE	1
22		3/8-16x3/4 H.H.C.S.	4
23	710-003	TOGGLE SWITCH	1
24	486-022	CL3503 1/2HP, 1PH	1
	486-002	CL3509 1HP, 1PH	
25	291-002	FRAME	1
26		1/2-20x1/2 H.H.C.S.	2
27		4x36" SANDING BELT	1
28	701-008	IDLER SPINDLE	1

KALAMAZOO INDUSTRIES, INC. 6856 East K Ave. Kalamazoo, MI 49048
 269-382-2050 PH 269-382-0790 FAX
www.kalamazooindustries.com